

**PERMIT**

**CITY OF NAPOLEON, OHIO — DEPT. OF BUILDING & ZONING**  
255 W. Riverview Avenue, Napoleon, Ohio 43545 (419) 592-4010

Permit No. 0999 Date March 25, 1985

Job Location 525 W. Maumee Address Valuation \$ 5000.00

Owner Breth Greggs Name Address 525 W. Maumee

Contractor Blue Water Pools Name Telephone No. 893-4854

Address 1212 Conant Maumee

Electric Contractor Owner

Plumbing Contractor \_\_\_\_\_

Mechanical Contractor \_\_\_\_\_

**This permit is issued for work described in the plans, specifications, and/or application submitted, as approved by the Building Commissioner of the City of Napoleon, Ohio. Work shall conform to all pertinent construction and land use Codes and Ordinances.**

**PAID**  
**MAR 25 1985**  
**CITY OF NAPOLEON**

**Work Information:**

Residential Single Commercial \_\_\_\_\_ Industrial \_\_\_\_\_  
No. dwelling units

New Construction \_\_\_\_\_ Addition XXXX Remodel \_\_\_\_\_

Brief Description of Work 12' X 24' above ground pool

ISSUED BY Richard G. Hayman Building Official DEPT. OF BUILDING & ZONING

**It is the owners or contractors responsibility to call the Building Department for the following (x) inspections:**

- \_\_\_\_\_ Footing excavation prior to placing concrete.
- \_\_\_\_\_ Footing drains and foundation prior to backfill.
- \_\_\_\_\_ Prepared sub-grade prior to placing concrete floor slab.
- \_\_\_\_\_ Sanitary sewer
- XXXX Rough-in electrical, plumbing and service framing prior to installing wall board.
- XXXX Final electrical, plumbing and heating.
- \_\_\_\_\_ Final building inspection, prior to occupancy.

**PERMIT & FEES**

Building Permit	\$ <u>16.50</u>
Electrical Permit	\$ <u>6.00</u>
Plumbing Permit	\$ _____
Mechanical Permit	\$ _____
Demolition Permit	\$ _____
Zoning Permit	\$ _____
Sign Permit	\$ _____
Water Tap	\$ _____
Sewer Tap	\$ _____
Temp. Elec.	\$ _____
Other	\$ _____
<b>TOTAL FEES</b>	\$ <u>22.50</u>
<b>LESS FEES PAID</b>	\$ <u>16.50</u> <i>3/25/85</i>
<b>BALANCE DUE</b>	\$ <u>6.00</u>

**Permit is not valid until all fees are paid in full, and shall be void if work is not started within six months of date above.**



# PERMIT

CITY OF NAPOLEON, OHIO — DEPT. OF BUILDING & ZONING  
255 W. Riverview Avenue, Napoleon, Ohio 43545 (419) 592-4010

Permit No. \_\_\_\_\_ Date March 25, 1985  
Job Location \_\_\_\_\_ Address \_\_\_\_\_ Valuation \$ 1000.00  
Owner \_\_\_\_\_ Name \_\_\_\_\_ Address \_\_\_\_\_  
Contractor \_\_\_\_\_ Telephone No. 593-1054  
Address \_\_\_\_\_  
Electric Contractor \_\_\_\_\_  
Plumbing Contractor \_\_\_\_\_  
Mechanical Contractor \_\_\_\_\_

This permit is issued for work described in the plans, specifications, and/or application submitted, as approved by the Building Commissioner of the City of Napoleon, Ohio. Work shall conform to all pertinent construction and land use Codes and Ordinances.

### Work Information:

Residential \_\_\_\_\_ Commercial \_\_\_\_\_ Industrial \_\_\_\_\_  
No. dwelling units  
New Construction \_\_\_\_\_ Addition \_\_\_\_\_ Remodel \_\_\_\_\_  
Brief Description of Work \_\_\_\_\_

ISSUED BY \_\_\_\_\_ Building Official \_\_\_\_\_ DEPT. OF BUILDING & ZONING

It is the owners or contractors responsibility to call the Building Department for the following (x) inspections:

- \_\_\_\_\_ Footing excavation prior to placing concrete.
- \_\_\_\_\_ Footing drains and foundation prior to backfill.
- \_\_\_\_\_ Prepared sub-grade prior to placing concrete floor slab.
- \_\_\_\_\_ Sanitary sewer
- \_\_\_\_\_ Rough-in electrical, plumbing and service framing prior to installing wall board.
- \_\_\_\_\_ Final electrical, plumbing and heating.
- \_\_\_\_\_ Final building inspection, prior to occupancy.

Permit is not valid until all fees are paid in full, and shall be void if work is not started within six months of date above.

**PAID**

MAR 25 1985

CITY OF NAPOLEON

### PERMIT & FEES

Building Permit	\$ <u>16.50</u>
Electrical Permit	\$ <u>8.00</u>
Plumbing Permit	\$ _____
Mechanical Permit	\$ _____
Demolition Permit	\$ _____
Zoning Permit	\$ _____
Sign Permit	\$ _____
Water Tap	\$ _____
Sewer Tap	\$ _____
Temp. Elec.	\$ _____
Other	\$ _____
<b>TOTAL FEES</b>	\$ <u>22.50</u>
<b>LESS FEES PAID</b>	\$ <u>16.50</u>
<b>BALANCE DUE</b>	\$ <u>6.00</u>

# INSPECTION RECORD

UNDERGROUND		ROUGH-IN & FINAL			
Type	Date	By	Type	Date	By
<b>PLUMBING</b>	Sewer Connection		Drainage, W. & Vent		
	Building Sewer		Water Piping		
	Water Piping		Condensate Lines		
			Indirect Waste		
				FINAL APPROVAL	
<b>ELECTRICAL</b>	Floor Ducts Raceways		Rough Wiring		
	Conduits & or Cable		Conduits/Cable		
	Grounding & or Bonding		Service Panel Switchboard		
			Subpanels		
			<input type="checkbox"/> Range <input type="checkbox"/> Dryer		
<b>MECHANICAL</b>	Refrigerant Piping		Refrigerant Piping		
	Ducts/Plenums		Ducts/Plenums		
			Ventilation <input type="checkbox"/> Supply		
			<input type="checkbox"/> Exhst.		
			Wall Construction		
<b>BUILDING</b>	Location, Set-backs, Esmt(s)		Crawl Space <input type="checkbox"/> Vent <input type="checkbox"/> Access		
	Excavation		Floor System(s)		
	Footings & Reinforcing		Roof System		
	Sub-soil Drain		Fire Wall(s)		
	Foundation Walls		Roof Cover Roof Drain		
Floor Slab					
FINAL APPROVAL BLDG. DEPT		Certificate of Occupancy Issued		#	

*1/28/85*

*1/28/85*

CITY OF NAPOLEON  
BUILDING INSPECTION DEPARTMENT  
APPLICATION FOR ELECTRICAL PERMIT  
(Please print or type)

The undersigned hereby makes application for installation or replacement of electrical equipment as herein specified, agreeing to do all such work in strict accordance with the City of Napoleon's adopted Electrical Codes.

Owner's Name Bret Griggs Address 525 West Maumee  
Electrical Contractor owner Telephone No. 592-2656

Address \_\_\_\_\_

General Contractor \_\_\_\_\_ Telephone No. \_\_\_\_\_

Address \_\_\_\_\_

Location of Project \_\_\_\_\_ Cost of Project \_\_\_\_\_

Work Information:

Residential SINGLE Commercial \_\_\_\_\_ Industrial \_\_\_\_\_  
No. Units

New \_\_\_\_\_ Service Change \_\_\_\_\_ Rewiring \_\_\_\_\_ Additional Wiring \_\_\_\_\_

Brief Description of Work: WIRING FOR POOL

Size of proposed service entrance \_\_\_\_\_ Number of new circuits 1

Type of proposed service entrance \_\_\_\_\_ Underground \_\_\_\_\_ Overhead \_\_\_\_\_

Require Temporary Electric \_\_\_\_\_ (Yes or No)

Total Floor Area - Commercial and Industrial only \_\_\_\_\_ sq. ft.

Additional Information: \_\_\_\_\_

\*Ground fault circuit interrupter protection is required on all 120-volt single phase, 15 and 20 amp. Circuits which are part of a temporary electric service; and also on bathroom, outdoor, and garage receptacles in all dwelling units. Art. 220-8 N.E.C.

\*Application for permit shall be accompanied by two complete sets of plans including: Electrical layout and riser diagram. (For commercial and industrial work only).

Date \_\_\_\_\_ Applicant's Signature \_\_\_\_\_

**PAID**  
MAR 25 1985  
CITY OF NAPOLEON

PERMIT NO. 0999  
PERMIT FEE \$ 6.00

01A  
APR 2 1988  
OFFICE OF PROSECUTOR

CITY OF NAPOLEON  
 BUILDING INSPECTION DEPARTMENT  
 APPLICATION FOR BUILDING PERMIT  
 (Please print or type)

The undersigned hereby makes application for construction, installation, or alteration work as herein specified, agreeing to do all such work in strict accordance with the City of Napoleon's adopted Building Codes.

Location of project 525 W. Maumee Cost of project \$5000<sup>00</sup>/<sub>100</sub>  
 Owner's Name Brett Briggs Address 525 W Maumee  
 Contractor Blue Water Pools Telephone No. 893-4854  
 Address 1212 Conant Maumee Ohio

Lot Information: (Not required for siding job)

Lot No. \_\_\_\_\_ Subdivision \_\_\_\_\_  
 Zoning District \_\_\_\_\_ Lot Size \_\_\_\_\_ ft. X \_\_\_\_\_ ft. Area \_\_\_\_\_ sq. ft.  
 Setbacks: Front \_\_\_\_\_ Right Side \_\_\_\_\_ Left Side \_\_\_\_\_ Rear \_\_\_\_\_

Work Information:

Residential SINGLR Commercial \_\_\_\_\_ Industrial \_\_\_\_\_  
 New Construction \_\_\_\_\_ Addition X Remodel \_\_\_\_\_  
 Accessory Building \_\_\_\_\_ Siding \_\_\_\_\_

Brief Description of Work: ----- 12 x 24 Pool (Specific Type)

Size: Length \_\_\_\_\_ Width \_\_\_\_\_ No. of Stories \_\_\_\_\_  
 Area: 1st Floor \_\_\_\_\_ sq. ft. Basement \_\_\_\_\_ sq. ft.  
 2nd Floor \_\_\_\_\_ sq. ft. Accessory Bldg. \_\_\_\_\_ sq. ft.  
 3rd Floor \_\_\_\_\_ sq. ft. Other \_\_\_\_\_ sq. ft.

Additional Information: \_\_\_\_\_

APPLICATION FOR PERMIT SHALL BE ACCOMPANIED BY TWO COMPLETE SETS OF PLANS INCLUDING: ELEVATIONS, FLOOR PLANS, CROSS SECTIONS AND PLOT PLAN. IF ADDITION OR REMODELING, SHOW ALL EXISTING STRUCTURES AND THEIR SIZE AND LOCATION. ALL PLANS SHALL BE DRAWN TO SCALE.

Date 3/25/85 Applicant's Signature [Signature]

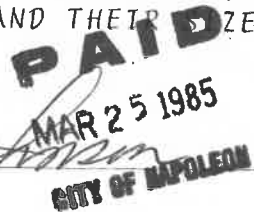

PERMIT NO. 0999  
 PERMIT FEE \$ 16.50

ALL INFORMATION CONTAINED  
HEREIN IS UNCLASSIFIED  
DATE 08-14-2008 BY 60322 UCBAW



Brett Griggs

592-2656

525- W. Maumee

Napoleon, Ohio

12x24-4' above ground Pool

\$5000<sup>00</sup>

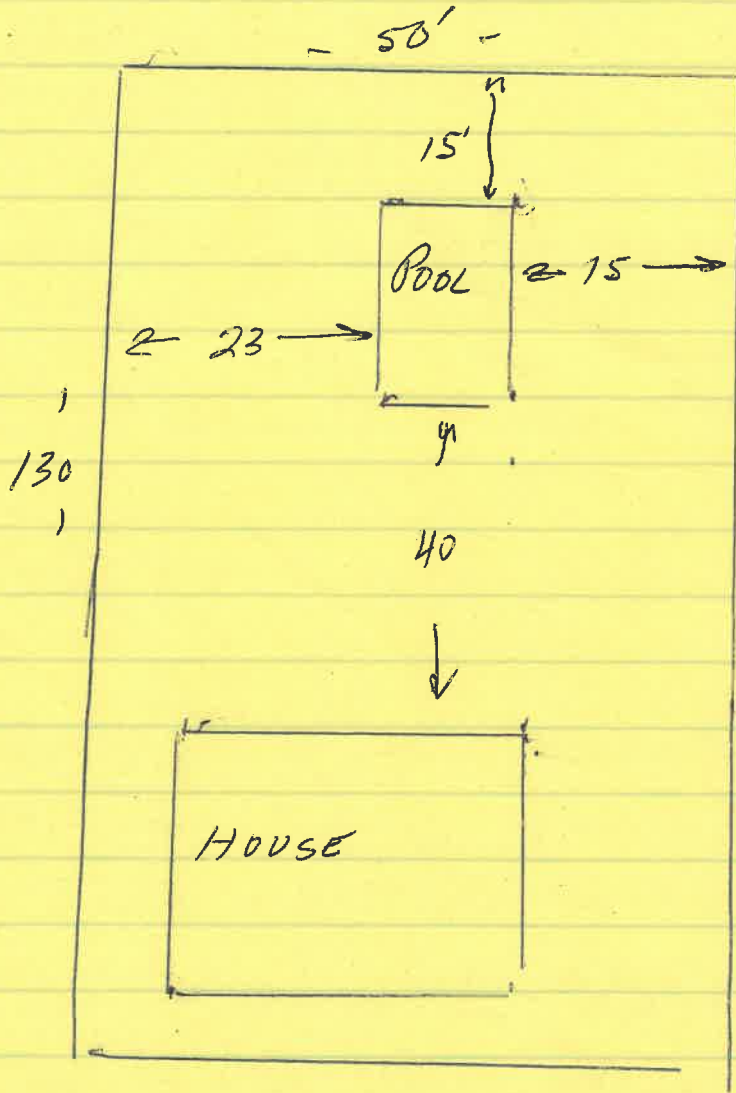

Blue Water Pools 1212 Conant

Maumee, Ohio

893-4854



# Olympic POOLS

One of the strongest and safest  
above-ground pools  
Self-fenced...  
stairgate can be locked  
to safeguard children

Available in 4' to 8' depths, the same as an inground pool. Will not raise your taxes in most counties. Pool can be dismantled and moved to a new location. Choice of 8' or 12' patio, fully carpeted for cool feet, non-slip safety to give special consideration to lounging and sunbathing as well as outdoor entertainment.



Olympic Pools available in eight sizes to fit your yard and budget. Enjoy the luxury and quality at a price your family can afford!

# One of the strongest pools money can buy...

## Olympic Pool Package includes:

- Pressure Treated fencing and top rail.
- 8 ft. patio and walk around deck, fully carpeted for cool feet, non-slip (choice of colors).
- 3/4" thick side wall and decking constructed of pressure treated wood—.40 ground contact treated.
- Decorating aluminum side panels (choice of colors).
- 4" steel channel—top and bottom—5.4 lbs. per ft. wgt. for strength.
- Bridge construction suspension bars.
- Recirculating main drain in deepest part of pool.
- In-wall skimmer and water return.
- Stainless steel ladder in pool.
- Heavy-duty filter, pump and motor—complete turn-over of water in pool every six hours.
- Vacuum sweeper, hand-leaf skimmer, vacuum hose, back-wash hose, and test kit.

## 30 Year Limited Warranty

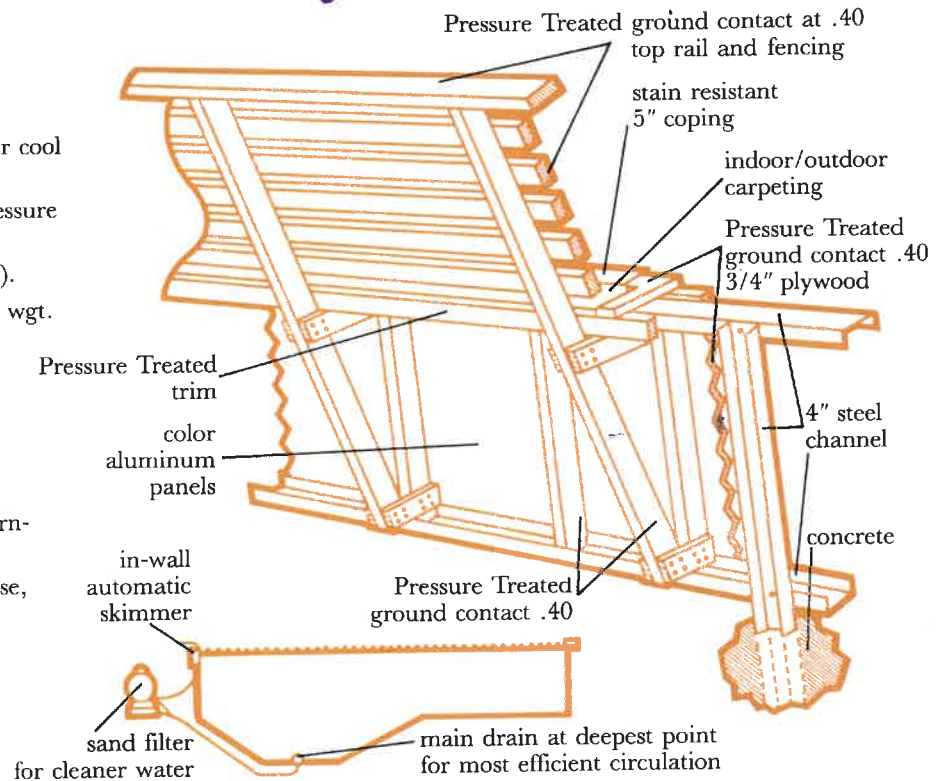

Olympic Pools offers a variety of sizes, especially for you to fit your yard and budget.

Outside Dimensions	Swim Area	Depth
17' x 32'	12' x 20'	4'
17' x 36'	12' x 24'	4'-7"
17' x 40'	12' x 28'	4'-7"
17' x 44'	12' x 32'	4'-7"
21' x 36'	16' x 24'	4'-7"
21' x 44'	16' x 32'	4'-7'10"
23' x 48'	18' x 36'	4'-8'4"
25' x 56'	20' x 40'	4'-8'4"

If any of the above sizes do not fit, ask your dealer to contact our engineering department. We will build it special for you.



1981 NSPI Gold Medal Design Award Winner

See your Olympic Dealer



The bitterness of poor quality remains long after the sweetness of low price is forgotten.

TM

**OLYMPIC POOLS**  
**1212 CONANT**  
**Maumee, Ohio 43537**  
**(419) 893-4854**